

STRIP PICK AREA FIXTURE

MFSPA

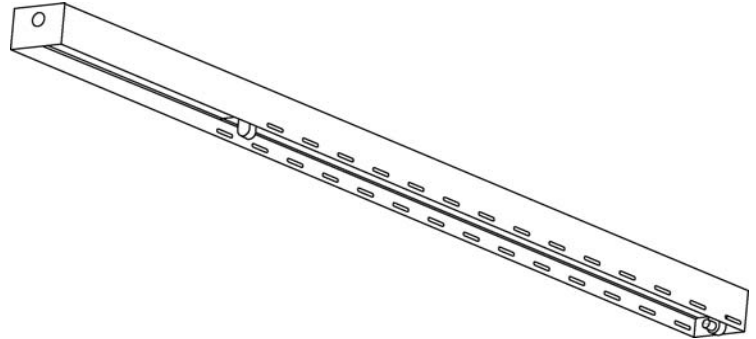

Application

Pick Conveyor Areas

Construction

Reflectors: Precision formed, high performance, 91% total reflectance white pre-painted aluminum.

Body: Body, ends and brackets are manufactured from .032 cold rolled steel and have white post fabricated baked enamel finish. The body of fixture is constructed for additional strength and reduction of air infiltration.

Ballast: Standard ballast are high performance electronic, Class P, non PCB, sound rated A, UL certified.

Mounting: fixture may be surface mounted.

Electrical

UL listed wire rated for required temperature and voltage. Lamps are secured with pressure locking sockets.

Warranty

One year standard warranty on fixture. Ballast carries 3-5 year manufacture warranty.

Options

Lamps, Ballast, Sensor and Reflector. (See available options)

Features

- 28 side light slots for side light.
- Reinforced construction with welding ends.
- Available in 1 T8 Lamp configuration
- Optional supplied lamps are available in various CRI ratings, temperature colors and rated life Ballast and wiring access
- No tools ballast and wiring access.
- Instant Restrike
- Dimming/Occupancy sensor compatible

Ordering Information

Use the Flow chart below to configure the part number. Actual part number may vary due to configuration.

MFSPA	Type SPA STRIP FIXTURE PICK AREA
	Fixture Size 72: 72" long x 4" wide
	Number of Lamps Req'd 14: 1-4'
	Ballast T8H - T8 "H" (120-277v) T8N - T8 "N" (120-277v)
	Optional Reflector Material W - White aluminum 91% TR U - Ultimate aluminum 95% TR
	Optional Sensor <input type="checkbox"/> - All Lamps <input type="checkbox"/> - Portion of Lamps
	Options See Options Sheet <input type="checkbox"/> - Lamps <input type="checkbox"/> - Ballast <input type="checkbox"/> - Reflector